

Model #: DFLT-5MPW



Features:

- 5 MP CMOS image sensor
- High Performance 5MP Resolution
- Compatible with 5MP TVI, 4MP TVI, Analog
- UTC, OSD, DWDR, 3D DNR, Smart
- 3.6mm Fixed Lens
- 1 EXIR Built in IR LEDs, (120 Ft. Night Vision)
- Vandal Resistant IP66 Weatherproof
- True Day/Night
- 3 Years Warranty

We reserve the right to modify product design and specification without notice and without incurring any obligation

For more information please contact a DSS Sales Representative

Toll Free: 1.888.467.8812 · Fax: 1.609.431.0932 · Email: sales@dss-cctv.com

www.dss-cctv.com

Technical Specifications

Model No.	DFLT-5MPW
Camera	
Image sensor	1/2.7" Progressive Scan CMOS
Min. illumination	0.01 Lux @ (F1.2,AGC ON),0 Lux with IR /0.014 Lux @ (F1.4,AGC ON),0 Lux with IR
Shutter time	1 / 25 s to 1 / 50,000 s
Lens	3.6mm Angle of View: 80.9°
Lens mount	M12
Day & night	ICR
Digital noise reduction	3D DNR
Wide dynamic range	DWDR
Synchronization	Internal synchronization
HD Video Output	1 Analog HD output Yellow
CVBS Output	Compatible with 5MP TVI, 4MP TVI, Analog
S/N Ratio	More than 52dB
Image	
Max. Image Resolution	2592 (H) × 1944 (V)
Signal System	NTSC
Frame rate	5MP@20fps
Image settings	Saturation, brightness, contrast, sharpness adjustable through client software or web browser
BLC	Supported
General	
Operating conditions	(-22°F ~ 140 °F) humidity 90% or less (non-condensing)
Power supply	12 VDC
Power consumption	Max. 4W
Weather proof rating	IP66
IR range	Up to 120 ft
Dimension	4.69" × 3.94"
Weight	1.54 Lbs

We reserve the right to modify product design and specification without notice and without incurring any obligation

For more information please contact a DSS Sales Representative

Toll Free: 1.888.467.8812 · Fax: 1.609.431.0932 · Email: sales@dss-cctv.com
www.dss-cctv.com

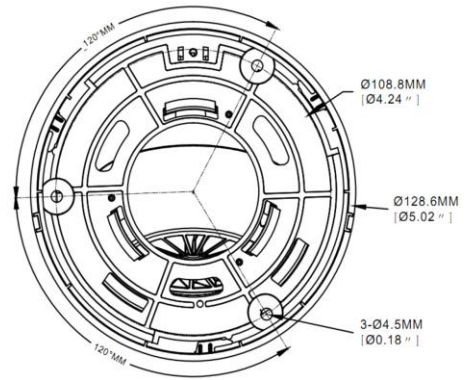
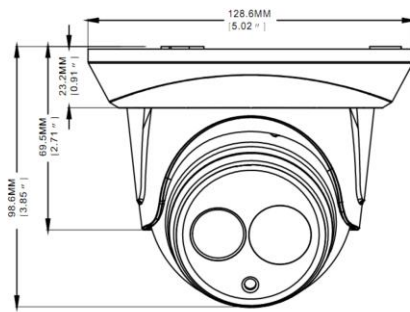
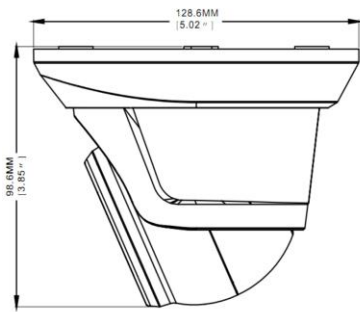

We reserve the right to modify product design and specification without notice and without incurring any obligation

For more information please contact a DSS Sales Representative

Toll Free: 1.888.467.8812 · Fax: 1.609.431.0932 · Email: sales@dss-cctv.com
www.dss-cctv.com