



ANALOG CAMERA

Quick Guide

FISHEYE

COMPONENT

As for each sales country, accessories are not the same.

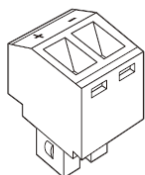
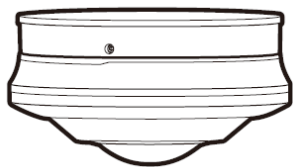

ANALOG CAMERA
Quick Guide
FISHEYE

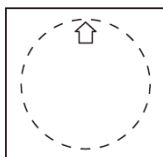

INSTALLATION



INSTALLATION

1

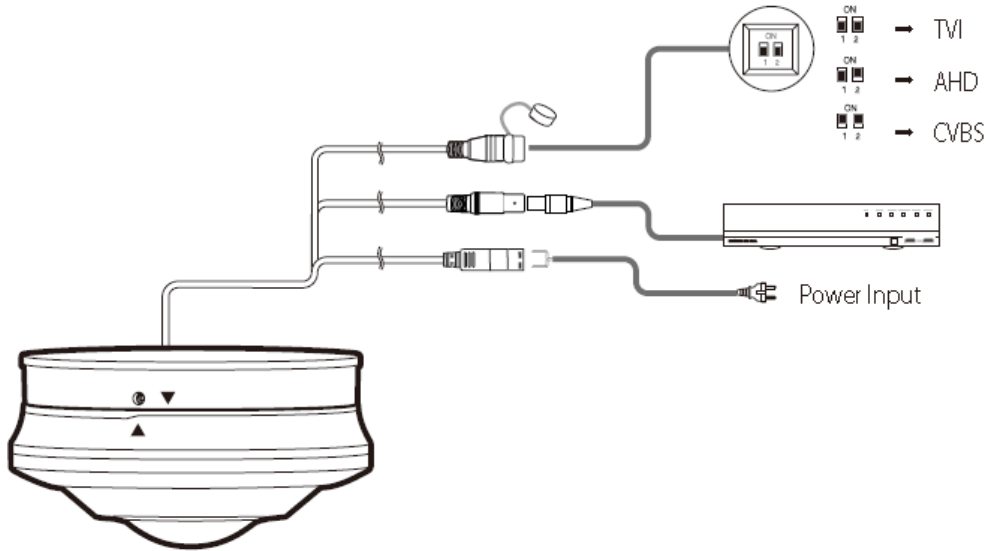

2

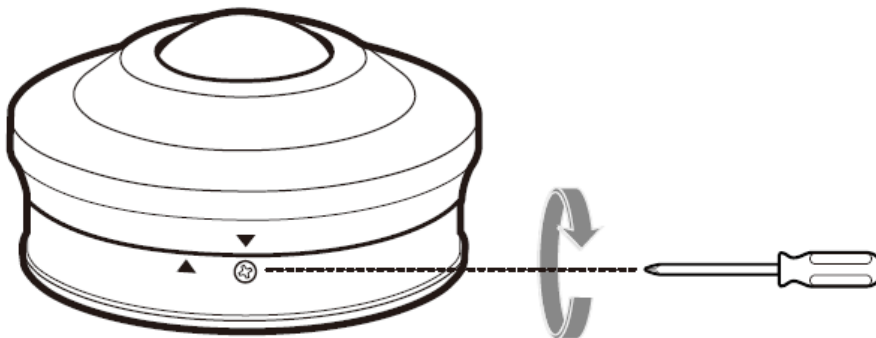

INSTALLATION

3

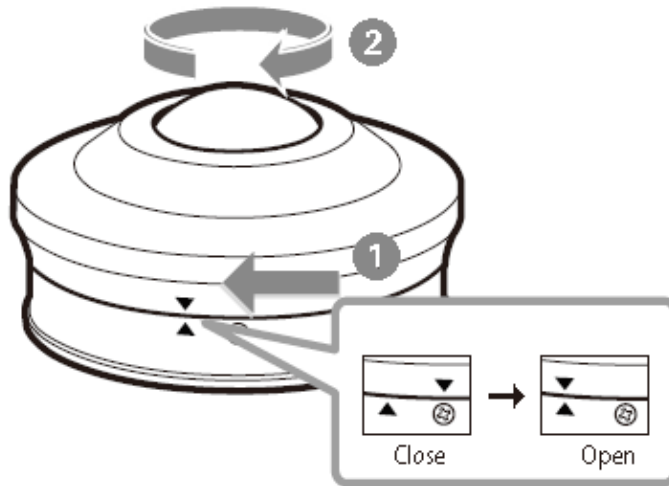

4

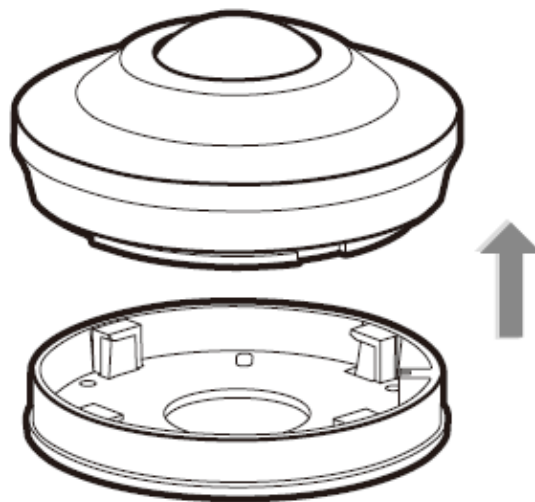

INSTALLATION

5

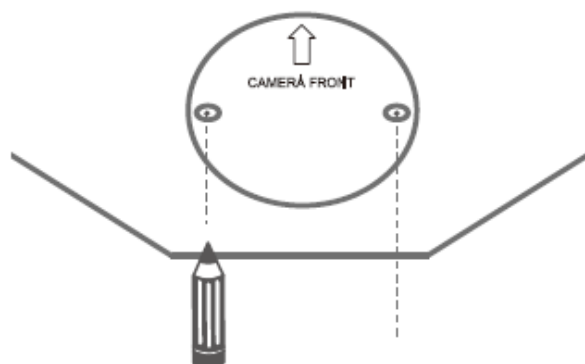

6

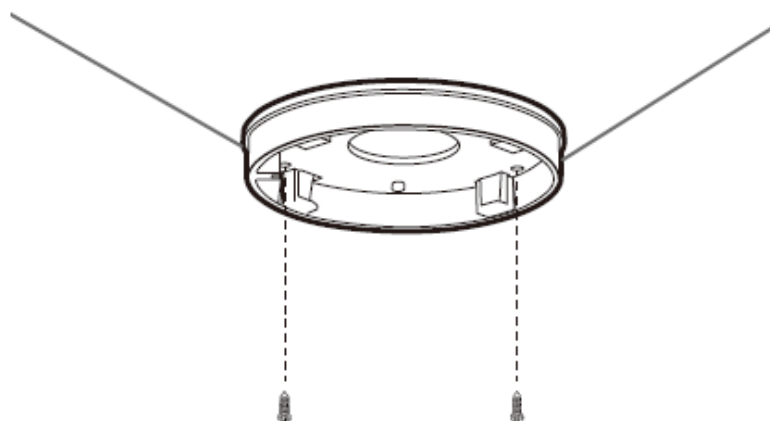

INSTALLATION

7

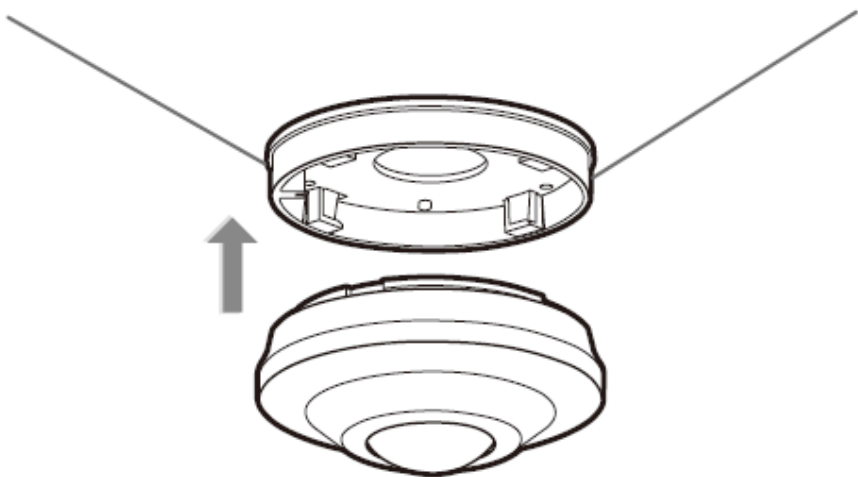

8

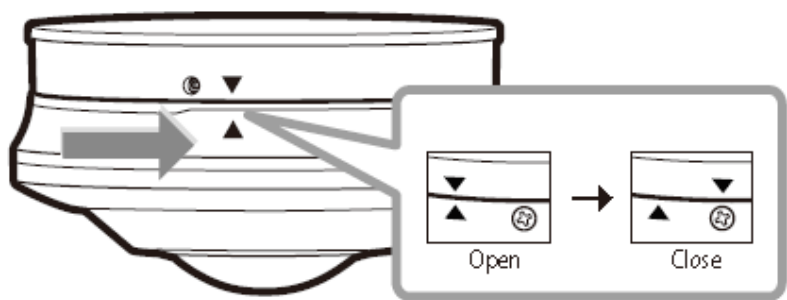

INSTALLATION

9

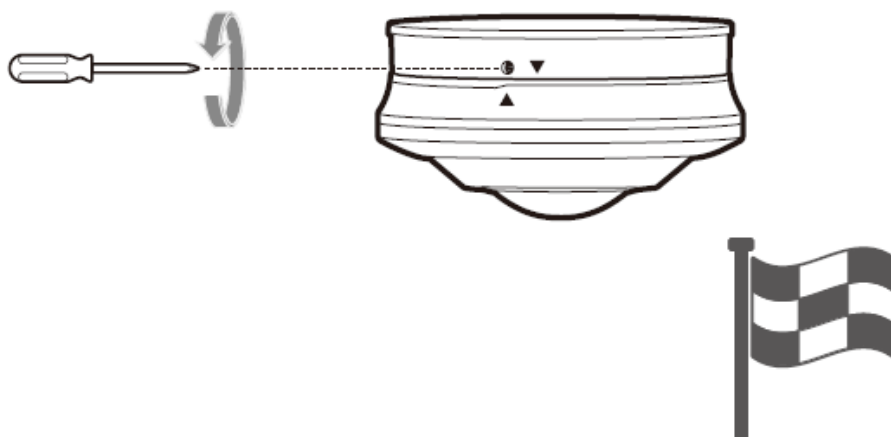

INSTALLATION (OPTIONS)

1

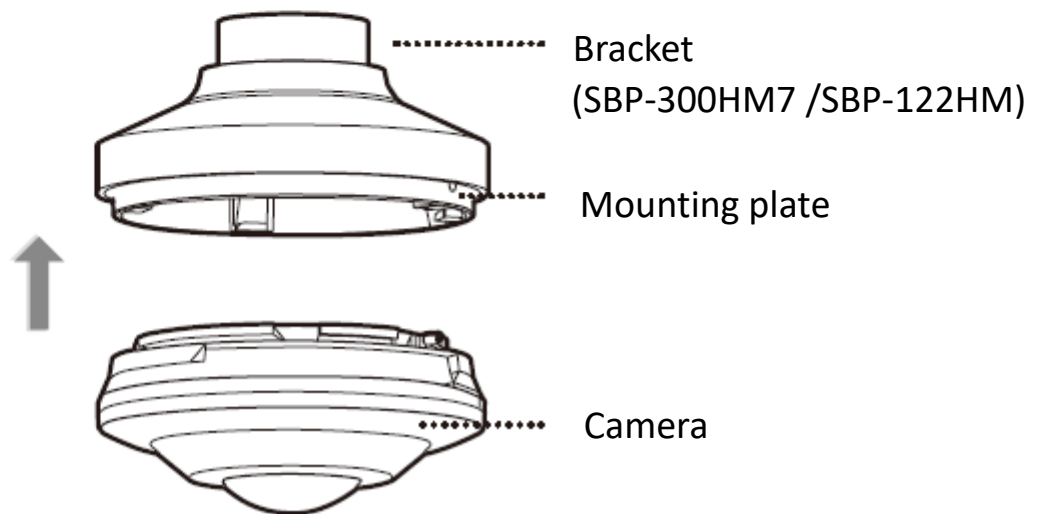
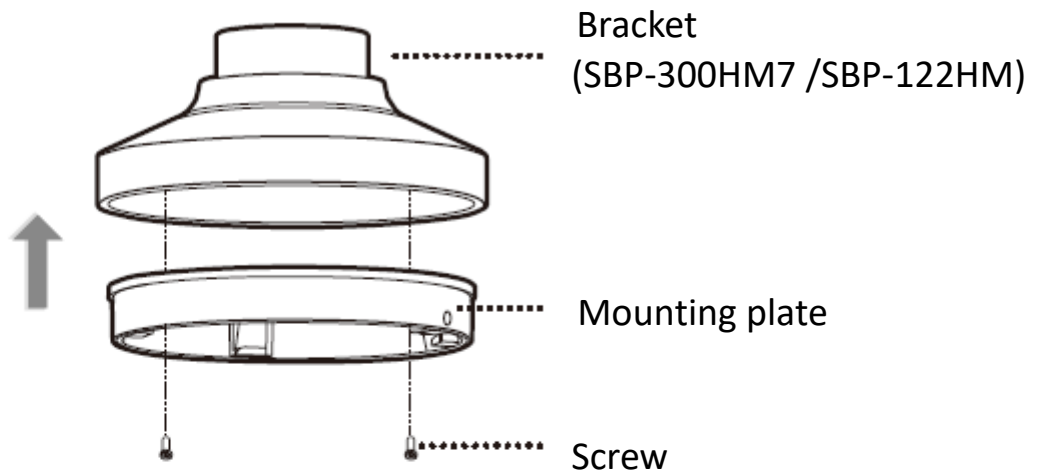

Warranty Card

Dear User:

Thanks for purchasing our product, in order to offer you better after sales service. Please complete the Warranty Card and Product Registration Card carefully, then send the completed card to franchiser or our Exclusive Sales Agent.

Product Description: _____

Product Model No.: _____

Date of Purchase: _____

Invoice(P/O) No.: _____

User Name: _____

Telephone: _____ FAX: _____

Address: _____ E-Mail: _____

Franchiser or exclusive sales agent: _____

Telephone: _____

Warranty Record	Repair Date	Repair Item	Person

Remark: 1)Presentation of Warranty items, please refer to back.

2)The card will be valid after 15 days of purchase when the franchiser or Exclusive sales agent chop.

----- Cut along the dashed -----

Product Registration Card

Product Description: _____

Product model No.: _____

Date of Purchase: _____

Invoice(P/O) No.: _____

User Name: _____

Telephone: _____ FAX: _____

Address: _____ E-Mail: _____

Franchiser or exclusive sales agent: _____

Telephone: _____

Product Warranty Presentation

Warranty Period:

Since the date of purchase. Exchange service after 3 months of purchase, repair service after 1 year of purchase.

Warranty items:

- 1 Before you use the product , please read the <User Manual> carefully.
- 2 You can share the Warranty service after you buy our product and send the completed card our franchiser or exclusive agent.
- 3 Based on the Warranty items ,you can use the free charge repair service only when you show the card under right operation of the product.
- 4 Please reserve /keep the Warranty card carefully if you need us to repair the product.
- 5 you are charged for repairing under below condition
 - 1)Beyond the Warranty period
 - 2)Physical damage to unit
 - 3)wrong operation under high temperature/pressure,deep;strong electrimagnetic interference.
 - 4) Not followingthe in struction manual or incorrect operation
- 6 we will ignore product, under below condition.
 - 1) Attempted repair by themselves.
 - 2) Problem caused by software or virus.
- 7The card is only valid in China.

----- Cut along the dashed -----

Your suggestion on our product is highly appreciated. We will keep tracing and developing to product high quality product for you.

Thanks for your co-operation

Yours Suggestion

--

